



X100™ Convertible Filter Housing and Accessories



Maximizing Filtration Efficiency • Minimizing Downtime • Reducing Filtration Costs

FSI has been serving the industry for over 25 years and has earned an ISO 9000 certification and worldwide recognition as a one-source provider of liquid filtration solutions.

At **FSI** we control the manufacturing process of all of our components, this control helps us to provide you with products that are not only top quality, but cost effective too.

Meeting & Exceeding World Production Standards... **And Yours.**

FSI fabricates liquid filtration products to meet or exceed international manufacturing specifications. In fact, many of our products have established new standards for industrial filtration.

With production facilities in Europe, South America, and North America,

FSI serves markets worldwide.

When your product depends on quality, you can depend on **FSI**.



X100™ Convertible Filter Housing.

The Right Choice for Many Applications and for Many Reasons.

FSI's X100™ Convertible Filter Housing provides an excellent, low-cost alternative to other types of filter housings.

FSI X100™ is Lightweight and Chemical-Resistant.

Manufactured from polypropylene with a UV inhibitor for all-weather durability, X100™ housings are strong, lightweight and economical. Resistant to a wide range of chemicals for a wide range of industrial applications, to precisely fit your particular needs.

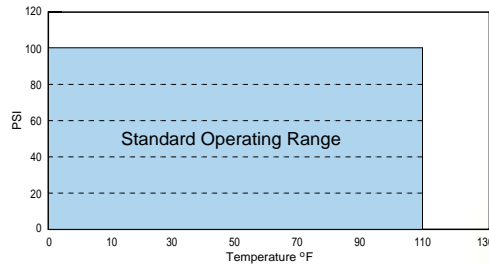

Operating Range for X100™ Filter Housing

Easy Cleaning is Another X100™ Trademark.

FSI engineered the X100™ convertible filter housing with a “clean wall” design, a smooth interior surface that allows faster, easier manual cleaning or in-place flushing.

The X100™ Filter Housing is Convertible.

Designed to accept either a bag filter or a cartridge filter, the FSI X100™ filter housing allows you to choose the filter media and construction to precisely fit your filtering needs.

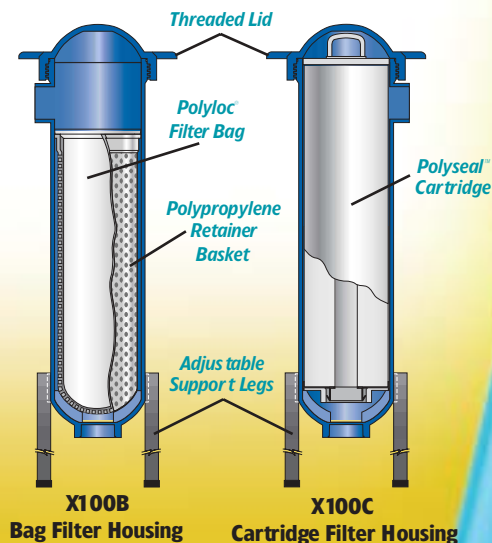

No Sump Disassembly is Required for Filter Changes.

Because the X100™ is top loaded with a specially developed threaded lid and gasket, filter elements can be changed without disassembling the sump and without additional tools for tightening. With the X100™, changing the filter requires much less time than with many other types of filter housings.

The Positive Sealing of Both Bag and Cartridge Filters.

The X100™ Convertible Filter Housing, along with the Polyloc® seal point of our X01™ filter bags and the Polyseal™ seal point of our X20™ filter cartridges, creates a positive seal and eliminates the chance of fluid by-pass.



Additional X100™ Attributes.

The X100™ Convertible Filter Housing can be easily converted to accept either a filter bag or filter cartridge.

To convert the housing:

- To filter bag operation: order the X100™ Plastic Basket.
- To filter cartridge operation: order the Cartridge Plate and Plate Gasket.

Replacement parts for the X100™ Convertible Filter Housing are also available through FSJ .

At FSJ, Service and Technology Work Together to Provide Filtration Solutions.

In addition to the X100™ filtering system, FSJ offers a broad line of vessels, filters, custom filter products, absorbent media, and accessories to fit most any filtration requirements.

FSJ team members are committed to working with our customers to create effective filtration solutions. If your goals are to reduce costs and increase efficiencies in your liquid filtration processes, call FSJ today. We'll begin the dialogue by having a direct sales representative or dealer gather vital information about your facilities, operations, and processing requirements. Experienced FSJ engineers will then work with you to design and build a liquid filtration system that specifically meets your needs.

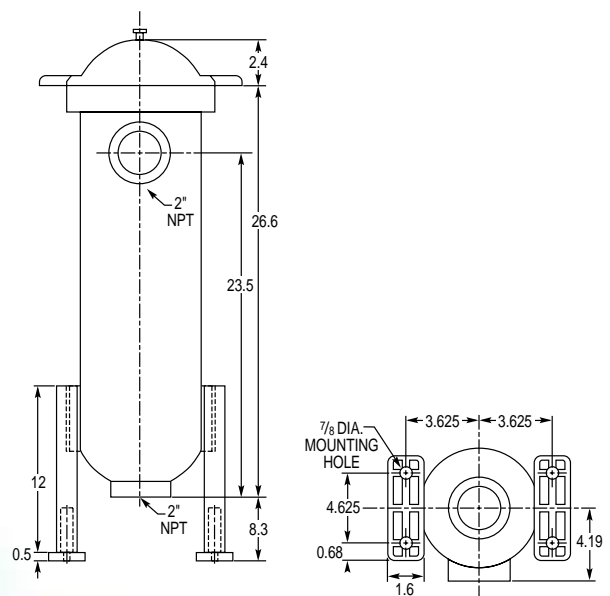

FSI X100™ Filters.

Whatever your application, FSI's X100™ filter housing is highly adaptable. A choice of filter elements and a complete line of accessories allow the X100™ to be your best filter choice.

X01™ Filter Bag.

Measuring 6" in diameter by a length of 20", the X01™ Filter Bag has 2 square feet of surface area (0.186 square meters), making it equivalent to a standard #1 size bag. The X01™ is fitted with the patented Polyloc® Ring that seals directly against the wall of the filter housing and eliminates the chance of fluid by-pass.

A heavy-duty Polypropylene Restrainer Basket supports the X01™. The Polyloc Ring sits directly against the basket collar for additional bag support.

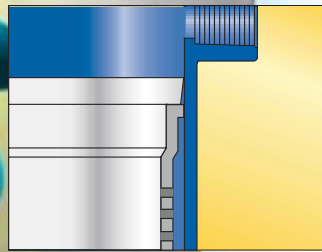

X01™ Cutaway

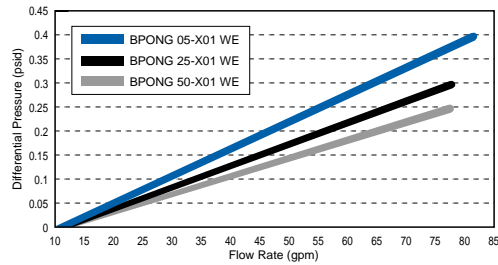

Clear Water Pressure Drop FSI BPONG X01™ Bags

Maximum flow rate GPM is the MAXIMUM FLOW RATE recommended through the vessel without filter bags installed using water as a base. Any increase in fluid viscosity, or the installation of filter bags, will reduce the maximum GPM figures significantly. To achieve the filtration efficiency required, the suggested max. flow rate is 45-55 GPM.

X20™ Filter Cartridge.

The X20™ Polyseal™ Cartridge is a steep pore gradient, depth filter designed to have a large dirt loading capacity. The X20™ measures 5.5" in diameter, with a length of 23.25", yielding a total cartridge volume of 500 cubic inches. In laboratory tests, the X20™ has outperformed standard 10" cartridges by holding 20 times the volume of dirt.

The design of the X20™ Polyseal™ Cartridge features a single open end that directs fluid from outside the cartridge in through the filter. A built-in handle on the cartridge top assists in seating and removing the X20™. The cartridge bottom is equipped with FSI's patented Polyseal™ End Fitting to ensure a by-pass-free sealing without the need for double O-rings or flat gaskets. Fitting securely into the cartridge plate, the X20™ does not require springs, hold-down plates or center posts.

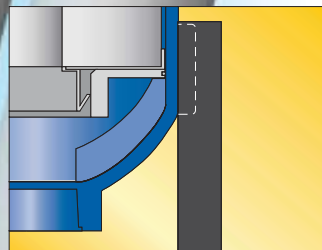

X20™ Cutaway

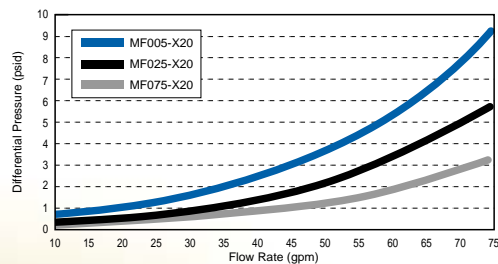

Clear Water Pressure Drop FSI X20™ Cartridges 5.5" OD 23.25" Length

Maximum flow rate GPM is the MAXIMUM FLOW RATE recommended through the vessel without filter cartridges installed using water as a base. Any increase in fluid viscosity, or the installation of filter cartridges, will reduce the maximum GPM figures significantly. To achieve the filtration efficiency required, the suggested max. flow rate is 45-50 GPM.

FSI X100™ Accessories.

X100™ Plastic Leg Stands.

Lightweight molded plastic leg assemblies are designed to mount directly on the X100™ Convertible Filter Housing, providing an economical means for supporting the vessel during installation and operation.



X100™ Plastic and Metal Leg Stands

X100™ Metal Leg Stands.

Tripod leg stands are available in either carbon steel or 304 stainless steel for heavy-duty vessel support. Dual rubber-lined metal bands and bolt tightening assemblies assure a secure installation.

Cone Base Stand for the X100™.

The X100™ Cone Base Stand comes with the option of a 2" NPT elbow or a T-pipe fixture to suit different piping configurations. Made of 100% polypropylene, the cone base can be mounted directly to the floor to form a solid base for the housing.



X100™ Cone Base Stand

X100™ Portable Filtration System.

FSI introduces its new X100™ Portable Filtration System. The cart utilizes bag filters to filter debris before the pump. This technology eliminates the need for a separate strainer basket for the pump. The system is designed to filter at a flow rate of 50-60 gallons per minute. Bags are available to filter in a range from 1 micron to 100 microns. With the bags removed the cart has 2 strainer baskets that will hold over 4 gallons of filtered material. The entire assembly is mounted on a hand dolly/cart and is easily transported as well as stored.

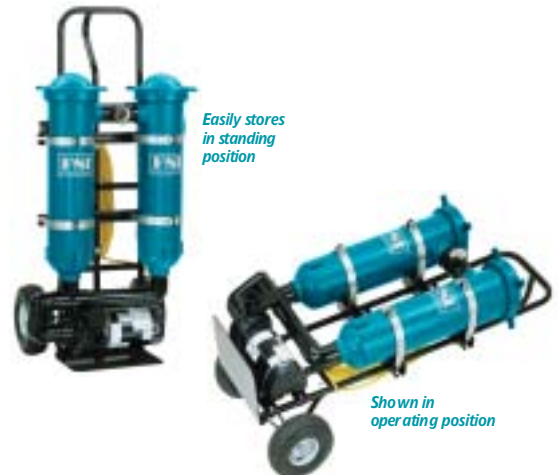

*Easily stores
in standing
position*

*Shown in
operating position*

X100™ Portable Filtration System

DPGX100™ Series Differential Pressure Gauge.

FSI offers a simple, effective, and economical way to maintain optimum performance of the X100™ filter system by indicating the proper time to change out filter elements. The visual indicator changes from green (clean filter media) to red to alert the user that the filter is dirty.

- Available in 2 pressure ranges: 6-8 PSID or 15-20 PSID
- Made of glass-filled nylon/stainless steel wetted materials (check for compatibility)
- Includes a Viton Seal/Teflon-coated spring



X100™ Differential Pressure Gauge

Metal Wall Mounting Brackets.

Mounting Brackets offers maximum flexibility for application configurations. Sturdy construction; metal bands can be positioned along bracket to accommodate piping, gauges and lids.



X100™ Wall Mounting Brackets

X100™

CONVERTIBLE FILTER HOUSING

FEATURES

Filter elements top loaded

Polypropylene construction

Convertible

Positive sealing

Clean wall design

FDA, NSF and CE mark

BENEFITS

No sump disassembly

Lightweight, chemically resistant

Uses cartridges or bags

No fluid by-pass

Easy access for manual cleaning or in-place flushing

Meets certification requirements

HOUSING SPECIFICATIONS (ASME Code not required) - Housings are NOT NSF certified

Model No.	Description	Includes
X100B	Plastic Bag Vessel (BUNA)	Housing, Lid, Basket, Lid Gasket (BUNA)
X100BA	Plastic Bag Vessel (API)	Housing, Lid, Basket, Lid Gasket (API)
X100C	Plastic Cartridge Vessel (BUNA)	Housing, Lid, Cartridge Plate, Lid Gasket & Plate Gasket (BUNA)
X100CA	Plastic Cartridge Vessel (API)	Housing, Lid, Cartridge Plate, Lid Gasket & Plate Gasket (API)

Pressure Rating 100 PSIG @110°F Water Service. Approx. Weight 10 lbs. Port Size: 2" NPT or 2" BSP Threads available.
Lid Vent: 1/4" NPT. FDA approved and with CE mark.

NSF CERTIFIED COMPONENTS

Model No.	Description	Includes
X100CN	NSF Certified Plastic Cartridge Vessel	Housing, Lid, Cartridge Plate, Lid Gasket & Plate Gasket

Part No.	Description	Micron Rating	Material	Element Seat
X20	NSF Certified Filter Cartridge	1, 5, 10, 25, 50, 75, 100	Polypropylene	Polyseal™†

BAG FILTER - Bags are NOT NSF certified

Part No.	Description	Micron Rating	Material	Element Seat
BPONG [] X01	Filter Bag	1, 5, 10, 25, 50, 100	Polypropylene	Polyloc® Ring
BPMO [] X01	Filter Bag	100, 150, 200, 300, 600, 800	Polypropylene	Polyloc® Ring
BPOMF [] X01	Filter Bag	1, 2, 10, 25, 90,*	Polypropylene	Polyloc® Ring

* BPOMFOAX01 filter bag is a special purpose bag with a Micron rating of 25.

CARTRIDGE FILTER - Cartridges are available that are NOT NSF certified

Model No.	Description	Micron Rating	Material	Element Seat
CMMF [] X20	Cartridge	1, 5, 10, 25, 50, 75, 100	Polypropylene	Polyseal™†

One FSI Polyseal cartridge has 20 times the capacity of a standard 10" cartridge.

OPTIONS & REPLACEMENT PARTS - All are NOT NSF certified

Description	Description
Replacement Lid—No Gasket	304 Stainless Steel Tripod Legs
X100 Plastic Basket	Lid Gasket (BUNA)
Cartridge Plate	Lid Gasket (Viton®)
(2) Plastic Leg and Foot Assembly	Plate Gasket (BUNA)
Carbon Steel Tripod Legs	Plate Gasket (Viton®)

Patents Pending

Viton® is a registered trademark of Dupont Dow Elastomers.

† Provides a socket-fit positive seal in a single-open-end cartridge design. Based upon single-pass filtration test in accordance with ASTM F795-88 procedure.

There are no expressed or implied warranties, including the implied warranty of merchantability and fitness for a particular purpose not specific herein respecting this agreement or the product being sold hereunder or the service provided herein.

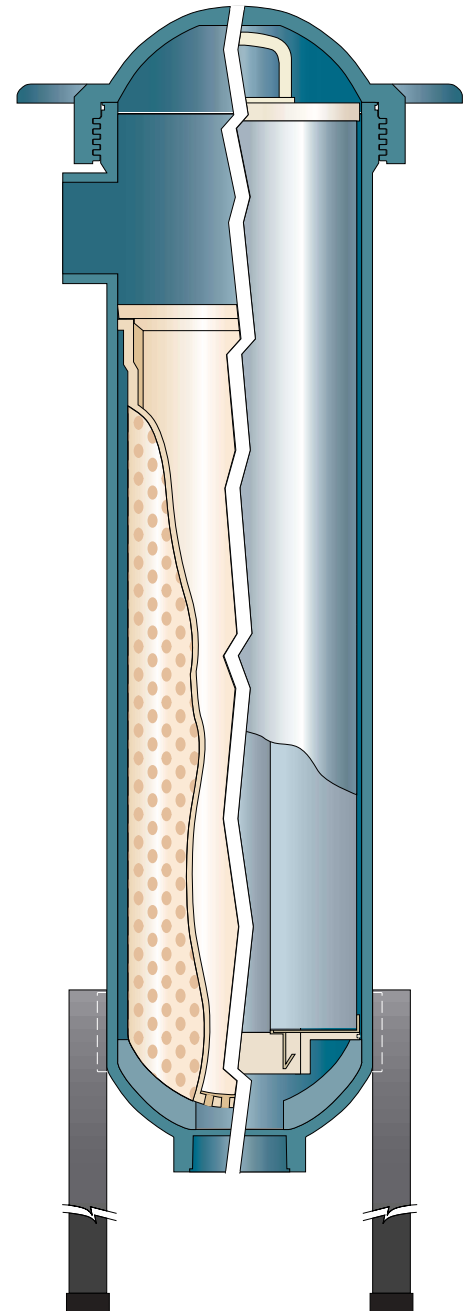

X100™ Convertible Filter Housing

The X100CN Pressure Vessel, and X20 Cartridge are tested and Certified by NSF International under ANSI/NSF Standard 42 for material requirements only.



Filter Specialists, Inc.

